

STR

STRATIFICATORE

STRATIFICATOR - DRAHTVERLEGUNG



STR



STR

STRATIFICATORE

La costante ricerca per migliorare la bobinatura del filo metallico ha portato la ditta **COMETO** a costruire un prodotto tecnologicamente avanzato in due diversi modelli: **STR 28** e **STR 40**, che si diversificano dai normali stratificatori oggi presenti sul mercato in quanto permettono una rapida inversione di corsa e non necessitano di alcuna manutenzione.

STR

STRATIFICATOR

The steady research in order to improve the coiling of the metallic wire has brought **COMETO** to manufacture a technologically advanced product in two different models: **STR 28** and **STR 40**, which diversify themselves from the normal stratifiers present on the market today, since they allow a quick stroke reversal and need no maintenance.

STR

DRAHTVERLEGUNG

Die unaufhörliche Forschung zur Verbesserung der Wicklung von Metalleitungen hat die Firma **COMETO** veranlaßt, ein technologisch avanciertes Produkt in zwei verschiedenen Ausführungen zu bauen—**STR 28** und **STR 40**, die sich von den bereits auf dem Markt befindlichen geläufigen Schichtern unterscheiden, da sie sich durch einen schnellen Umkehrlauf und Wartungsfreiheit auszeichnen.

1	Tipo Type / Typ	FMAX	A	B	C	D	d	E	F	G	H	L	N	O	P	Q	R	S	T
	STR-28	35	96	56	120	70	M8	95	35	220	180	200	∅11	138	8	44,5	168	∅11	∅30
	STR-40	70	110	60	140	88	M10	90	48	255	220	240	∅11	138	62	62,2	181	∅18	∅40

2	Tipo Type / Typ	SCELTA DELLA CORSA MASSIMA, DIMENSIONI L M E TIPO CINGHIA MAX. STROKE CHOICE, DIMENSIONS L M AND BELT TYPE MAX. HUB WAHL, ABMESSUNGEN L M UND RIEMENTYP													
STR-28	CINGHIA BELT / RIEMEN	600H	630H	660H	700H	750H	800H	850H	900H	1000H	1100H	1250H	1400H	1700H	
	CORSA STROKE / LAUF	321	359	397	448	511	575	638	702	829	956	1146	1337	1718	
		627	665	703	754	817	881	944	1008	1135	1262	1452	1643	2024	
	M	481	519	557	608	761	735	798	862	989	1116	1306	1497	1878	
STR-40	CINGHIA BELT / RIEMEN	600H	630H	660H	700H	750H	800H	850H	900H	1000H	1100H	1250H	1400H	1700H	
	CORSA STROKE / LAUF	235	273	311	362	425	489	552	616	743	870	1060	1251	1632	
		561	599	637	688	751	815	878	942	1069	1196	1386	1577	1958	
	M	415	453	491	542	605	669	732	796	923	1050	1240	1431	1812	

3	Tipo Type / Typ	TP	∅p	B1	L1	H1	H2	N1	N2	F1	F2	PI	PE	LT
	V28...	18H100	72,77	45	40	18	47	70	130	1/8" GAS	M6	60	76	86
	V40...	24H150	97,02	30	40	35	35	70	130	1/8" GAS	M6	85	100	111

4	Tipo Type / Typ	SCELTA PASSO / STEP CHOICE / AUSWAHL DES WICKELSCHRITTS RAPPORTO RIDUTTORE / REDUCER / REDUKTIONSVERHÄLTNIS										
		1/28	1/30	1/35	1/38	1/45	1/46	1/60	1/64	1/70	1/80	1/100
	STR-28	8,2	-	6,5	-	-	4,9	3,8	-	3,2	-	-
	STR-40	-	10,2	-	8,0	6,8	-	-	4,8	-	3,8	3,0

1 VISTA FRONTALE

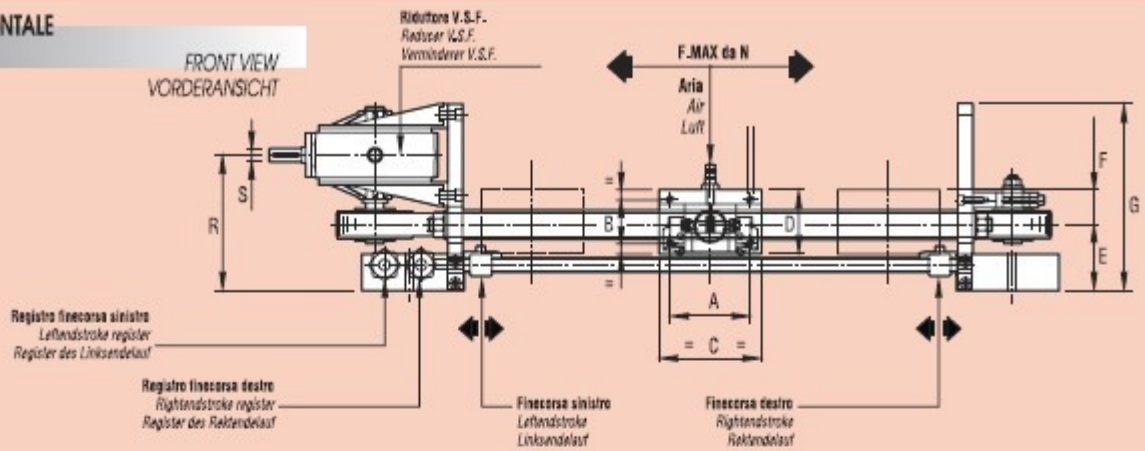

2 VISTA IN PIANTA

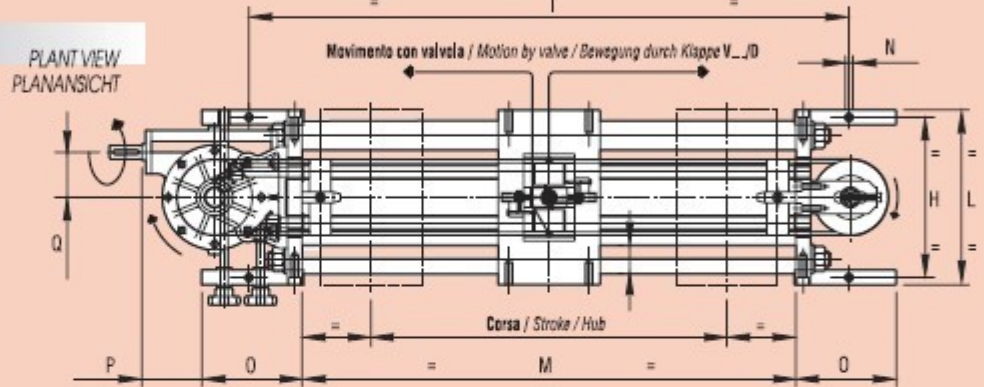

3 SCELTA VALVOLE IN FUNZIONE NEL SENSO DI ROTAZIONE CINGHIA

VALVE-TYPE CHOICE REFERRING TO THE BELT ROTATION WAY
KLAPPELTYP WAHL BEZ DER RIEMENDREHRICHTUNG

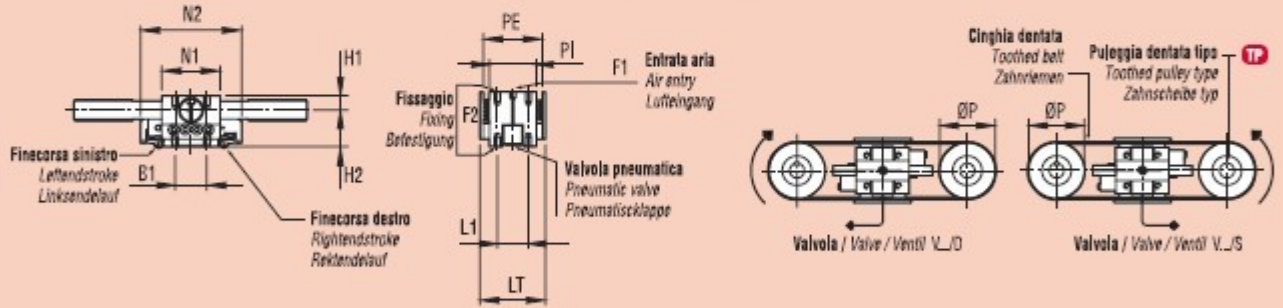

4 SCELTE PASSO AVVOLGIMENTO RAPPORTO D1/D2=1

DOLLER UP STEP CHOICE WITH RATIO D1/D2=1
AUSWAHL DES WICKELSCHRITTS MIT VERHÄLTNISS D1/D2=1

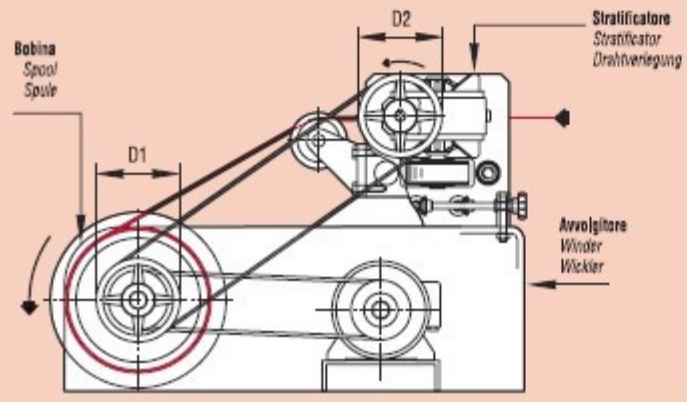

Tipo Type Typ	Valvola Valve Ventil	Corsa Stroke Hub	Passo Step Schritt
STR	40	D	1632 3,8



cometo



AITMAC, INC

ADVANCED INDUSTRIAL TECHNOLOGIES & MACHINES, INC

329 Rayette Rd, Unit 14, Concord, Ontario, L4K 2G1. Canada
E-mail: sales.aitmac.ca@gmail.com • <http://www.aitmac-ca.com>
Tel: (905) 761-6165 • Fax: (905) 761-6168

